



Bennett & Bennett

Contact

Bennett & Bennett Inc.
1744 Thomas Paine Pkwy
Centerville, Ohio 45459

January 21, 2015

Objective

To evaluate the electrical resistance properties of the ESD Work Surface samples. ANSI/ESD S 4.1-2006, a test procedure and standard published by the ESD Association, was used for this test series.

Materials Submitted for Test

5200 Series and 5300 Series ESD Work Surface Mats.

- A. Six, 5200 series, 2 layer rubber ESD mats – Thickness 1.5 mm (0.060 inches)
- B. Six, 5300 series, 2 layer rubber ESD mats – Thickness 2.0 mm (0.080 inches)
- C. All samples had dimensions of 10x24 inches.

Executive Summary

The work surface mats manufactured by Bennett & Bennett Inc. for product qualification testing meet the point to point and point to groundable point resistance requirements of ANSI/ESD S20.20-2014 when tested at both low and moderate relative humidity.

ANSI/ESD S4.1 – Work Surfaces

ANSI/ESD S4.1-2006 provides test procedures for evaluating the electrical resistance of work surface materials. ANSI/ESD S20.20-2014 defines the required limits for work surfaces that are to be used in an ESD control program where ESD sensitive devices are handled.

All testing was conducted in an environmental chamber set at 23⁰ C and 12% relative humidity. The samples were conditioned for 48 hours prior to testing. The resistance measurements, required by the test method, were made on the supplied samples. At the completion of the low humidity testing a new set of samples were conditioned in an environment set at 23⁰ C and 50% relative humidity for 48 hours. At the completion of the conditioning period the resistance measurements were repeated.

A Prostat PRS-801 Resistance System was used for all measurements. This resistance meter meets the “Resistance Measuring Meter” requirements of ANSI/ESD S4.1-2006.

According to ANSI/ESD S20.20-2014, an acceptable work surface will have a point to point and a point to groundable point resistance of less than 1.0×10^9 ohms.

Environmental Conditioning

1. A total of six specimens with minimum dimensions of 10x24 inches are required for each type of ESD work surface tested.
2. Three samples of each ESD work surface to be tested are placed in an environmental chamber preset to $23 \pm 1^{\circ}$ Celsius and $12\% \pm 3\%$ relative humidity for a minimum of 48 hours.
3. Three new samples of each ESD work surface to be tested are placed in an environmental chamber pre-set to $23 \pm 1^{\circ}$ Celsius and $50\% \pm 5\%$ relative humidity for a minimum of 48 hours.

General Test Procedure – Resistance to Groundable Point

1. Attach the resistance meter sensing lead to groundable point A and the voltage lead to a five pound electrode.
2. Place the electrode at position 1. Set the meter output to 10 volts and initiate a resistance measurement. If the resistance is less than 1×10^6 ohms record the value. If the resistance is greater than 1×10^6 ohms set the meter output to 100 volts and repeat the measurement. Record the resistance once the reading stabilizes. (See Figure 1)
3. Repeat the resistance to groundable point A for electrode positions 2 and 3.
4. Repeat steps 2 and 3 with the sensing lead attached to groundable point B.
5. Repeat for the remaining 2 samples.

At the completion of the resistance to groundable point testing perform a point to point resistance test as follows:

General Test Procedure – Resistance Point to Point

1. Attach the sensing lead to one five pound electrode and the voltage lead to a second five pound electrode.
2. Place the electrodes on the work surface per Figure 2A.
3. Set the meter output to 10 volts and initiate a resistance measurement. If the resistance is less than 1×10^6 ohms record the value. If the resistance is greater than 1×10^6 ohms set the meter output to 100 volts and repeat the measurement. Record the resistance once the reading stabilizes.
4. Re-position the electrodes per Figure 2B and repeat step 3.
5. Repeat steps 2 through 4 for the 2 remaining samples.
6. Place three untested samples of each ESD work surface to be tested in an environmental chamber preset to $23 \pm 1^{\circ}$ Celsius and $50\% \pm 5\%$ relative humidity for a minimum of 48 hours.
7. Repeat the Resistance to Groundable Point and the Resistance Point to Point Measurements.

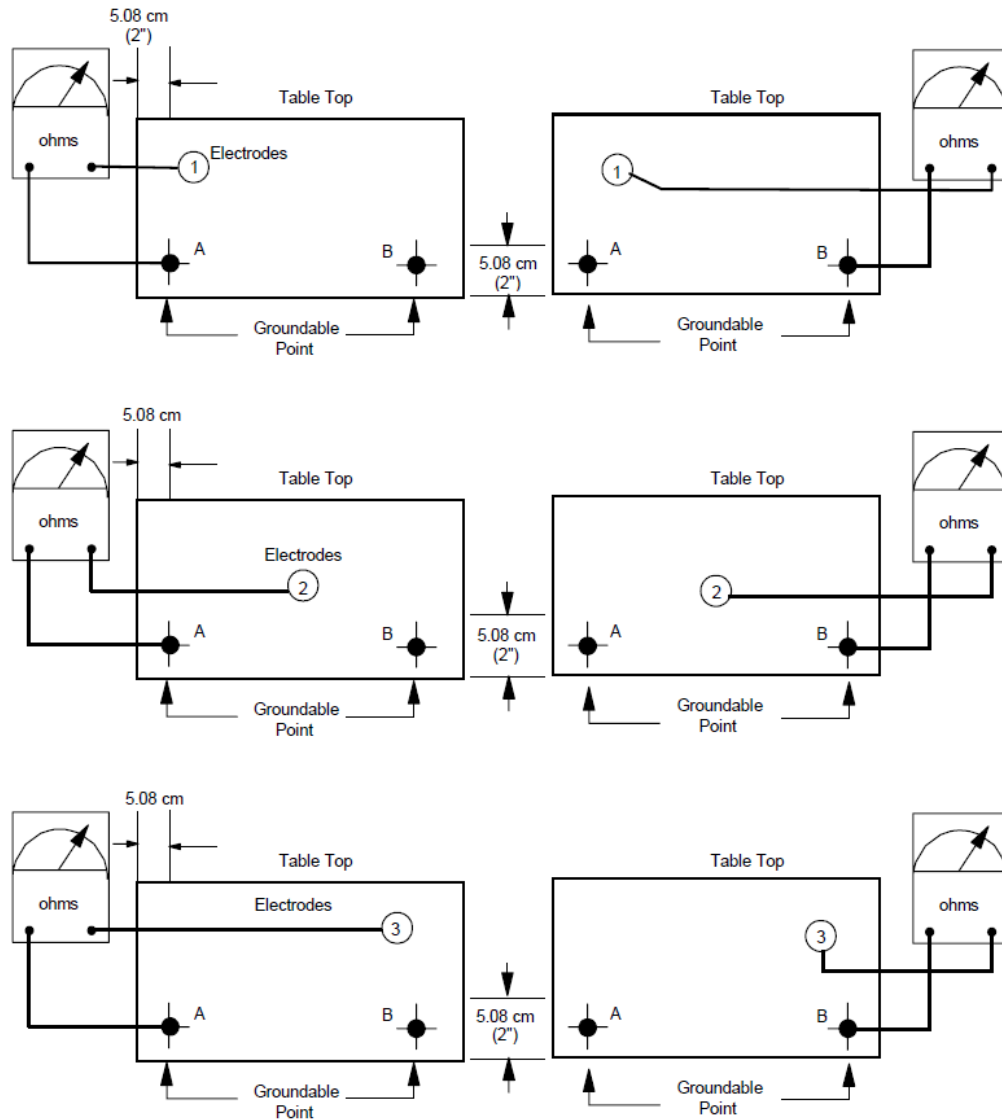

Figure 1 – Resistance to Groundable Point Testing

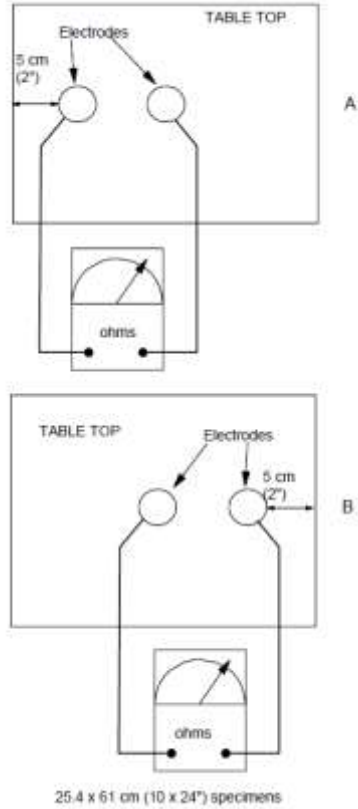

Figure 2 – Point to Point Resistance Testing

Data Calculations

The minimum, maximum, median and average resistance values for the work surfaces tested were calculated.

Low Relative Humidity Data

Work Surface Tested	RGpA			RGpB			Pt-Pt (Left to CTR)	Pt-Pt (CTR to Right)
	1	2	3	1	2	3		
Royal Blue Rubber 5200								
Sample 1	1.70E+07	1.90E+07	1.60E+07	1.60E+07	1.80E+07	1.60E+07	3.30E+07	4.00E+07
Sample 2	1.70E+07	1.60E+07	1.60E+07	1.70E+07	1.80E+07	1.70E+07	3.40E+07	3.30E+07
Sample 3	1.50E+07	1.60E+07	1.40E+07	1.70E+07	1.70E+07	1.50E+07	3.10E+07	3.50E+07
Minimum	1.40E+07							
Maximum	4.00E+07							
Median	1.70E+07							
Average	2.10E+07							

Work Surface Tested	RGpA			RGpB			Pt-Pt (Left to CTR)	Pt-Pt (CTR to Right)
Royal Blue Rubber 5300	1	2	3	1	2	3		
Sample 1	1.50E+07	1.80E+07	1.70E+07	1.60E+07	1.80E+07	1.70E+07	3.70E+07	3.90E+07
Sample 2	1.40E+07	1.60E+07	1.60E+07	1.40E+07	1.60E+07	1.60E+07	3.50E+07	3.80E+07
Sample 3	1.30E+07	1.30E+07	1.30E+07	1.20E+07	1.30E+07	1.30E+07	3.00E+07	3.10E+07
Minimum	1.20E+07							
Maximum	3.90E+07							
Median	1.60E+07							
Average	2.00E+07							

Moderate Relative Humidity Data

Work Surface Tested	RGpA			RGpB			Pt-Pt (Left to CTR)	Pt-Pt (CTR to Right)
Royal Blue Rubber 5200	1	2	3	1	2	3		
Sample 1	1.20E+07	1.40E+07	1.30E+07	1.20E+07	1.30E+07	1.20E+07	2.30E+07	2.60E+07
Sample 2	1.20E+07	1.50E+07	1.20E+07	1.20E+07	1.30E+07	1.10E+07	2.30E+07	2.70E+07
Sample 3	1.40E+07	1.40E+07	1.10E+07	1.20E+07	1.40E+07	1.20E+07	2.70E+07	2.70E+07
Minimum	1.10E+07							
Maximum	2.70E+07							
Median	1.30E+07							
Average	1.59E+07							

Work Surface Tested	RGpA			RGpB			Pt-Pt (Left to CTR)	Pt-Pt (CTR to Right)
Royal Blue Rubber 5300	1	2	3	1	2	3		
Sample 1	1.10E+07	1.20E+07	1.00E+07	1.00E+07	1.20E+07	1.10E+07	2.00E+07	2.10E+07
Sample 2	1.00E+07	1.20E+07	1.00E+07	1.10E+07	1.20E+07	1.10E+07	2.10E+07	2.50E+07
Sample 3	7.30E+06	8.50E+06	8.50E+06	7.60E+06	9.80E+06	9.50E+06	1.50E+07	1.60E+07
Minimum	7.30E+06							
Maximum	2.50E+07							
Median	1.10E+07							
Average	1.26E+07							