



ANSI / ESD S4.1 - 2006 Test Data

5300 Series Mats

To evaluate the electrical resistance properties of the 5300 Series mat we used ANSI / ESD S 4.1-2006, a test procedure standard that is produced by the ESD Association for examining test series data.

5300 Series matting meets the point to point and point to groundable point resistance requirements of ANSI / ESD S20.20 - 2014 when tested at both low and moderate relative humidity.

ANSI / ESD S4.1-2006 Test Procedure

According to ANSI / ESD S20.20-2014, an acceptable work surface will have a point to point and a point to groundable point resistance of less than 1.0×10^9 ohms.

ANSI / ESD S 4.1-2006 provides test procedures for evaluating the electrical resistance of work surface materials. ANSI / ESD S20.20-2014 defines the control limits for work surfaces that are to be used in an ESD control program where ESD sensitive devices are handled.

Testing of the 5300 Series was conducted in an environmental chamber set at 23°C and 12% relative humidity. The 5300 Series was conditioned for 48 hours prior to testing. At the completion of the low humidity testing a new set of samples was conditioned in an environment set at 23°C and 50% relative humidity for 48 hours. At the completion of the conditioning period the resistance measurements were repeated.

A Prostat PRS - 801 Resistance System meter was used for all measurements. This resistance meter meets the "Resistance Measuring Meter" requirements of ANSI / ESD S 4.1-2006.

Environmental Conditioning

1. A total of six samples with minimum dimensions of 10 x 24 inches are required for each type of mat tested.
2. Three samples of each mat to be tested are placed in an environmental chamber preset to $23 \pm 1^\circ\text{C}$ and $12\% \pm 3\%$ relative humidity for a minimum of 48 hours.
3. Three new samples of each mat to be tested are then placed in an environmental chamber preset to $23 \pm 1^\circ\text{C}$ and $50\% \pm 5\%$ relative humidity for a minimum of 48 hours.



ANSI / ESD S4.1 - 2006 Test Data

5300 Series Mats

General Test Procedure-Resistance to Groundable Point

1. Attach the resistance meter sensing lead to groundable point A and the voltage lead to a five pound electrode.
2. Place the electrode at position 1. Set the meter output to 10 volts and initiate a resistance measurement. If the resistance is less than 1×10^6 ohms record the value. If the resistance is greater than 1×10^6 ohms set the meter output to 100 volts and repeat the measurement. Record the resistance once the reading stabilizes. (See Figure 1)
3. Repeat the resistance to groundable point A for electrode positions 2 and 3.
4. Repeat steps 2 and 3 with the sensing lead attached to groundable point A.
5. Repeat for the remaining 2 samples.

General Test Procedure-Resistance Point to Point

1. Attach the sensing lead to one five pound electrode and the voltage lead to a second five pound electrode.
2. Place the electrodes on the mat per Figure 2A.
3. Set the meter output to 10 volts and initiate a resistance measurement. If the resistance is less than 1×10^6 ohms record the value. If the resistance is greater than 1×10^6 ohms set the meter output to 100 volts and repeat the measurement. Record the resistance once the reading stabilizes.
4. Re-position the electrodes per Figure 2B and repeat step 3.
5. Repeat steps 2 through 4 for the remaining samples.
6. Place three untested samples of each mat to be tested in an environmental chamber preset to $23 \pm 1^\circ\text{C}$ and $50\% \pm 5\%$ relative humidity for a minimum of 48 hours.



ANSI / ESD S4.1 - 2006 Test Data

5300 Series Mats

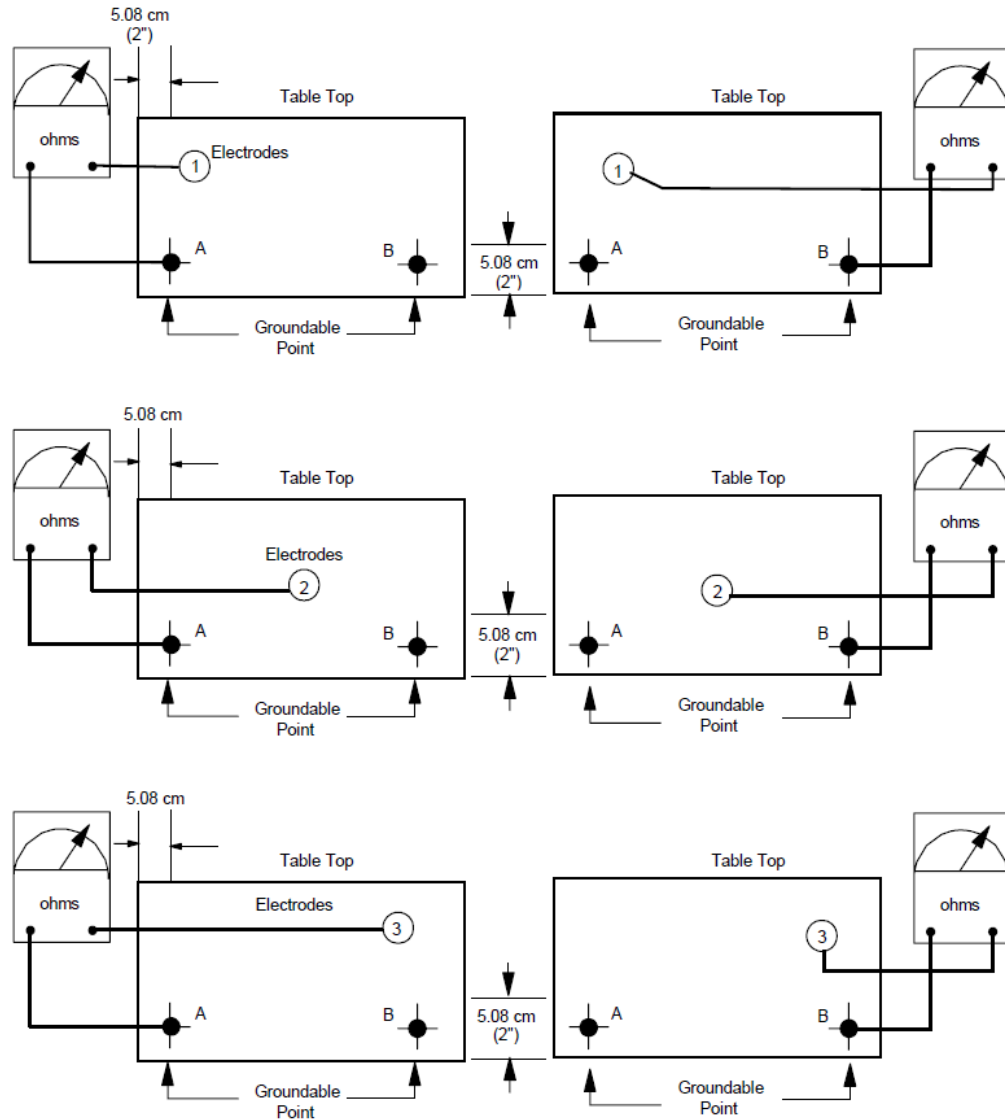

Figure 1 - Resistance to Groundable Point Testing



ANSI / ESD S4.1 - 2006 Test Data

5300 Series Mats

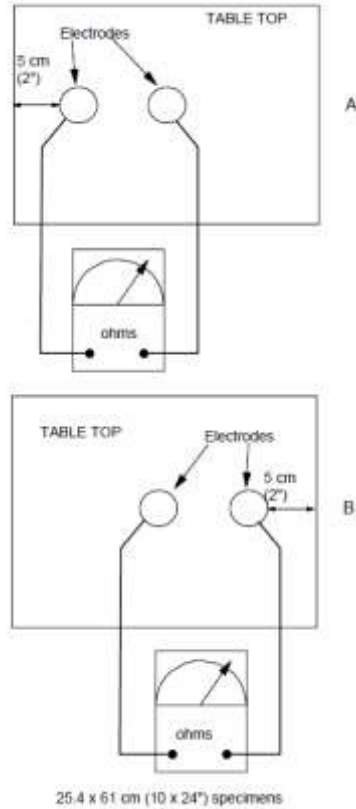

Figure 2 - Point to Point Resistance Testing



ANSI / ESD S4.1 - 2006 Test Data

5300 Series Mats

Low Relative Humidity Data

Mat Tested	RGpA			RGpB			Pt-Pt	Pt-Pt
							(Left to CTR)	(CTR to Right)
5300	1	2	3	1	2	3		
Sample 1	1.50E + 07	1.80E + 07	1.70E +07	1.60E +07	1.80E +07	1.70E +07	3.70E +07	3.90E +07
Sample 2	1.40E + 07	1.60E +07	1.60E +07	1.40E +07	1.60E +07	1.60E +07	3.50E +07	3.80E +07
Sample 3	1.30E + 07	1.30E +07	1.30E +07	1.20E +07	1.30E +07	1.30E +07	3.00E +07	3.10E +07

Minimum: 1.20E +07 Maximum: 3.90E +07 Median: 1.60E +07 Average: 2.00E +07

Moderate Relative Humidity Data

Mat Tested	RGpA			RGpB			Pt-Pt	Pt-Pt
							(Left to CTR)	(CTR to Right)
5300	1	2	3	1	2	3		
Sample 1	1.10E + 07	1.20E + 07	1.00E +07	1.00E +07	1.20E +07	1.10E +07	2.00E +07	2.10E +07
Sample 2	1.00E + 07	1.20E +07	1.00E +07	1.10E +07	1.20E +07	1.10E +07	2.10E +07	2.50E +07
Sample 3	7.30E + 07	8.50E +07	8.50E +07	7.30E +07	9.80E +07	9.50E +07	1.50E +07	1.60E +07

Minimum: 1.00E +07 Maximum: 9.80E +07 Median: 1.10E +07 Average: 1.26E +07